

SPOTUNE SUB

WIRELESS SUBWOOFER



User manual

INDEX

1	Important remarks	Page 4
2	Important safety instructions	Page 6
3	Introduction	Page 8
4	Setting up	Page 10
5	Packaging content	Page 13
6	Technical specifications	Page 14
7	Compliance & License	Page 15

1 . IMPORTANT REMARKS



The lightning flash with arrowhead symbol, within an equilateral triangle, is intended to alert the user to the presence of uninsulated “dangerous voltage” within the product’s enclosure that may be of sufficient magnitude to constitute a risk of electric shock to persons.



The exclamation point within an equilateral triangle is intended to alert the user to the presence of important operating and maintenance (servicing) instructions in the literature accompanying the appliance.

WARNING

(If applicable): The terminals marked with symbol of “ ” may be of sufficient magnitude to constitute a risk of electric shock. The external wiring connected to the terminals requires installation by an instructed person or the use of ready-made leads or cords.

WARNING

To prevent fire or shock hazard, do not expose this equipment to rain or moisture.



Class I (1) appliance

WARNING

This product must not be discarded, under any circumstance, as unsorted urban waste. Take to the nearest electrical and electronic waste treatment centre.



NOTE

Spottune company accepts no liability for any damage that may be caused to people, animal or objects due to failure to comply with the warnings above.

1 . REMARQUES IMPORTANTES



WARNING

Risk of electric shock
Do not open

AVIS

Risque de choc électrique
Ne pas ouvrir



Le symbole de l'éclair avec une pointe de flèche, dans un triangle équilatéral, est destiné à alerter l'utilisateur de la présence d'une " tension dangereuse" non isolée dans l'enceinte du produit qui peut être d'une amplitude suffisante pour constituer un risque de choc électrique pour les personnes..



Le point d'exclamation dans un triangle équilatéral est destiné à alerter l'utilisateur de la présence d'instructions importantes du fonctionnement et de maintenance dans la documentation accompagnant l'appareil.

ATTENTION (Le cas échéant): Les bornes marquées du symbole " " peuvent avoir une amplitude suffisante pour constituer un risque de choc électrique. Le câblage externe connecté aux bornes nécessite une installation par une personne qualifiée ou l'utilisation de fils ou cordons prêts à l'emploi.

ATTENTION Pour éviter tout risque d'incendie ou d'électrocution, n'exposez pas cet équipement à la pluie ou à l'humidité.



Appareil de classe I (1)

ATTENTION Ce produit ne doit en aucun cas être jeté en tant que déchet urbain non trié. Apportez-vous au centre de traitement des déchets électriques et électroniques le plus proche.



REMARQUE La société Spottune décline toute responsabilité pour tout dommage pouvant être causé à des personnes, des animaux ou des objets en raison du non-respect des avertissements ci-dessus.

2. IMPORTANT SAFETY INSTRUCTIONS

- 1.** Read these instructions.
- 2.** Keep these instructions.
- 3.** Heed all warnings.
- 4.** Follow all instructions.
- 5.** Do not use this apparatus near water.
- 6.** Clean only with dry cloth.
- 7.** Install in accordance with the manufacturer's instructions, and avoid covering the controlpanel as this can cause overheating.

- 8.** Do not install near any heat sources such as radiators, heat registers, stoves, or other apparatus (including amplifiers) that produce heat.

- 9.** Protect the power cord from being walked on or pinched particularly at the plugs, convenience receptacles, and at the point where they exit from the apparatus.

- 10.** Only use attachments/accessories specified by the manufacturer.

- 11.** Unplug the apparatus during lightening shorts or when unused for long periods of time.

- 12.** Refer all servicing to qualified personnel. Servicing is required when the apparatus has been damaged in any way, such as power supply cord or plug is damaged, liquid has been spilled or objects have fallen into the apparatus, the apparatus has been exposed to rain or moisture, does not operate normally, or has been dropped.

- 13.** Equipment is connected to a socket-outlet with earthing connection by means of a power cord.

- 14.** The marking information is located at the bottom of apparatus.

- 15.** The apparatus shall not be exposed to dripping or splashing and that no objects filled with liquids, such as vases, shall not be placed on the apparatus.

2. CONSIGNES DE SÉCURITÉ IMPORTANTES

- 1.** Lisez ces instructions.
- 2.** Conservez ces instructions.
- 3.** Tenez compte tous les avertissements.
- 4.** Suivez toutes les instructions.
- 5.** N'utilisez pas cet appareil près de l'eau.
- 6.** Utilisez uniquement un chiffon sec pour le nettoyage.
- 7.** Suivez les instructions d'installation du fabricant.

- 8.** N'installez pas cet appareil à proximité d'une quelconque source de chaleur, telle qu'un radiateur, une arrivée d'air chaud, un four ou tout autre appareil (y compris les amplificateurs) produisant de la chaleur.

- 9.** Protégez le cordon d'alimentation contre les risques de piétinement ou de pincement, notamment au niveau des fiches, des prises de courant et des branchements à l'appareil.

- 10.** Utilisez uniquement les fixations / accessoires spécifiés par le fabricant.

- 11.** Débranchez cet appareil pendant un orage ou en cas d'inutilisation prolongée.

- 12.** Confiez toute réparation à du personnel qualifié. Une réparation est nécessaire lorsque l'appareil a été endommagé de quelque façon que ce soit, par exemple, endommagement du cordon d'alimentation ou de la fiche électrique, renversement d'un liquide ou de tout objet sur l'appareil, exposition de l'appareil à la pluie ou à l'humidité, dysfonctionnement ou chute de l'appareil.

- 13.** L'équipement est connecté à une prise de courant avec mise à la terre au moyen d'un cordon d'alimentation.

- 14.** Les informations de marquage se trouvent au bas de l'appareil.

- 15.** L'appareil ne doit pas être exposé à des gouttes ou des éclaboussures et aucun objet rempli de liquides, par exemple des vases, ne doit pas être placé sur l'appareil.

3. INTRODUCTION

Spottune SUB

Spottune SUB is a wireless subwoofer, designed to be set up in minutes and used in combination Spottune Omni speakers, and addition to your spottune system

The Subwoofer can be placed on the floor, wall or ceiling mounted, and is wirelessly connected to Spottune stream.

Instructions for wall mounting, can be found on page 11

Instructions for ceiling installation, can be found on page 12

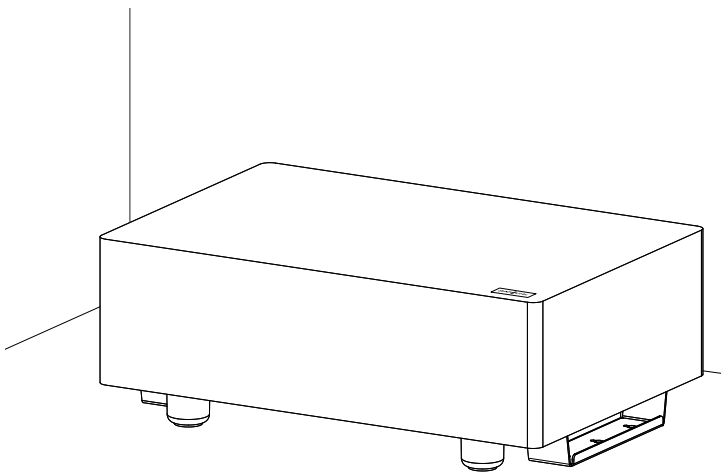

Placed on floor

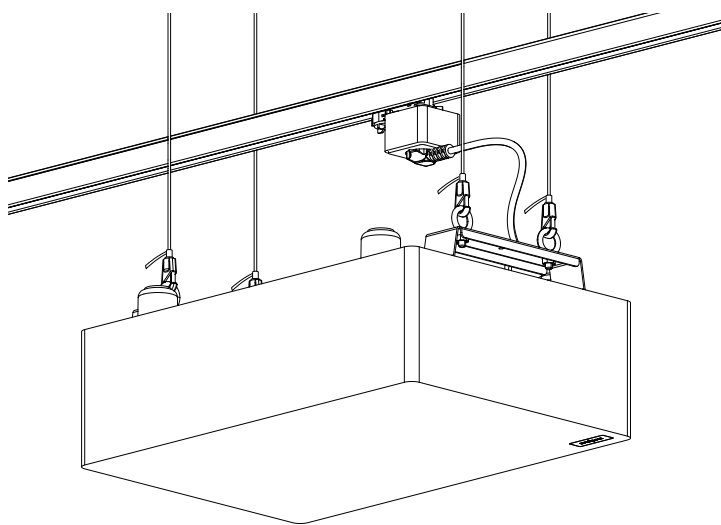

Suspended from ceiling, with power from tracks.

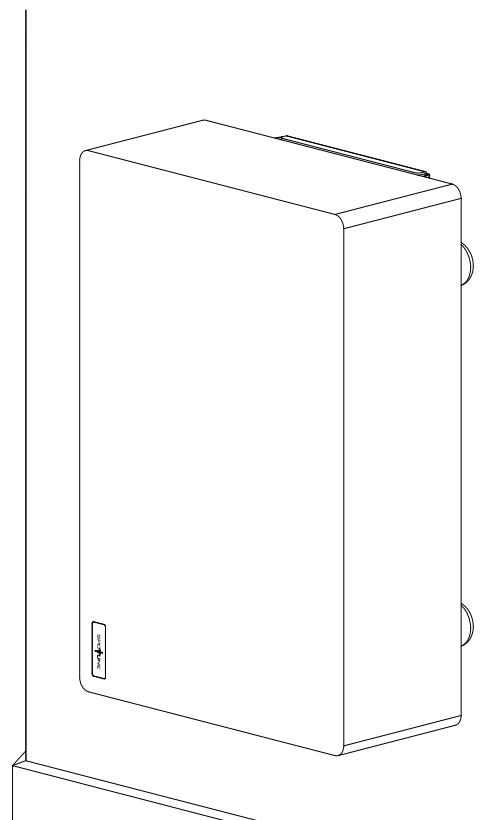

Mounted on wall

1. Status LED
2. USB Port for service, and update
3. Zone indicator. LED lights to indicate if SUB is connected to zone I or II
4. Zone button. Switch between zone I and II
5. Pair button. For pairing subwoofer with Spottune Stream - Transmitter
6. Volume buttons
7. AUX input
8. On/off button
9. Power inlet
10. Microphone

STATUS LED Lights

- No light** No power connected to the Subwoofer
- WHITE light** Booting up
- GREEN flash** Subwoofer is in pairing mode / process
- GREEN light** Connection established / ready
- RED flash** No connection to Spottune Stream
- RED light** Standby, no music signal from stream.
- YELLOW flash** Reset to factory default

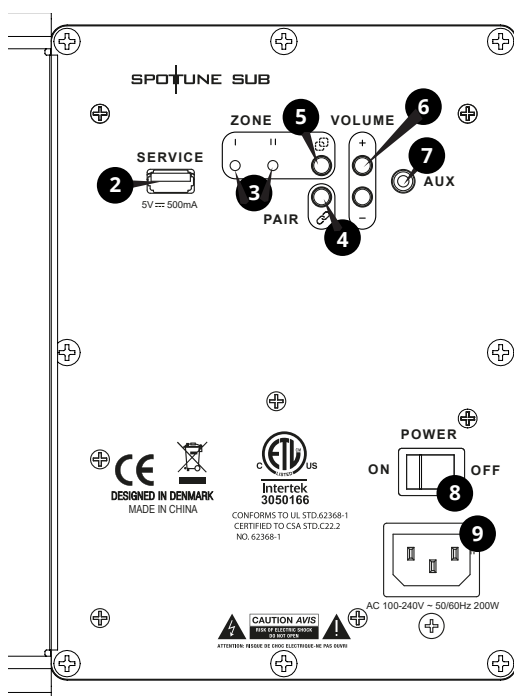

BACK

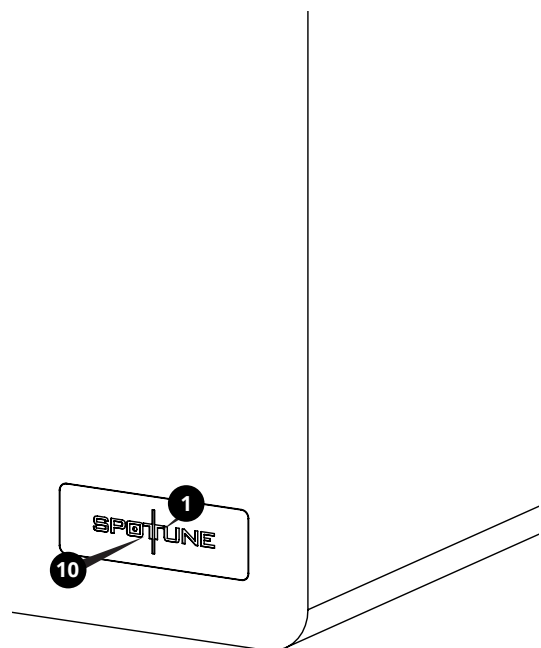

FRONT

4. SETTING UP

Placement

- Place Spottune SUB within range of the Spottune Stream
- Place Spottune SUB freely and visible, not in closed compartments.
- Avoid placing near or with blocking metal materials around the Subwoofer

Installation: Power

- Connect to AC outlet 100–240V, with supplied power cable

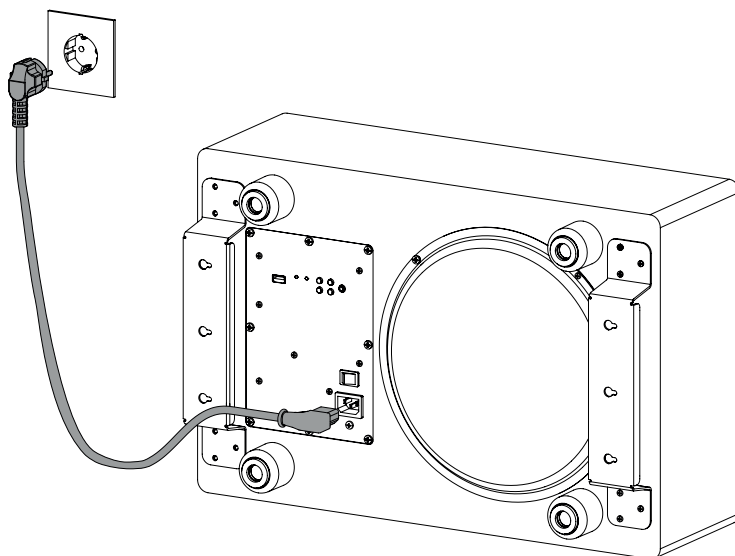

Connecting and pairing

- Spottune SUB is automatically in “PAIRING MODE” when powering up the first time. the “Status LED” is flashing green on the front of the subwoofer.
- Spottune SUB is automatically installed as “ZONE 1” - if you want to change the Subwoofer to “ZONE 2”, - press & hold the “Zone button” for 2 sec on Spottune SUB, to toggle between “ZONE 1” and “ZONE 2”.
- After powering up the Spottune SUB, power on your Spottune Stream. Spottune Stream is automatically in “PAIRING MODE” when powering on the first time, and will pair the Spottune OMNI or SUB to the chosen zone(s).
- To enter Pairing mode manually press and hold “Pair button” for 3 sec, first on Spottune SUB, followed by press and hold for 3 sec on the “Zone Button” of Spottune Stream. Spottune SUB and Stream will automatically pair, and SUB will appear on the display of Spottune stream.

Volume control

- The volume level of Spottune SUB can be adjusted either through Spottune Cloud, or manually by using the “Volume buttons” on the back of the subwoofer.

Factory Reset

- Press “Zone button” on Spottune SUB and hold for 30 seconds to factory reset the subwoofer. The “Status LED” will flash yellow to confirm the reset.

Mounting : Wall

WARNING WHEN INSTALLING, ALWAYS OBSERVE THE NATIONAL INSTALLATION AND ACCIDENT PREVENTION REGULATIONS

NOTE: DO ALL SETTINGS ON REAR PANEL, BEFORE MOUNTING SUB TO ITS PLACE.

Using the mounting template, place and mark up holes. Find suitable screws and wall anchors, (see minimum requirements below), and mount the screws in the wall. Mount the SUB by placing the premounted wallbrackets on the screws. Make sure the subwoofer is mounted solid. Tighten screws if necessary.

Minimum requirements for wall mounting:

Anchors: suitable for wall, minimum requirement 10 kg per anchor

Screws: minimum requirement 10 kg per screw

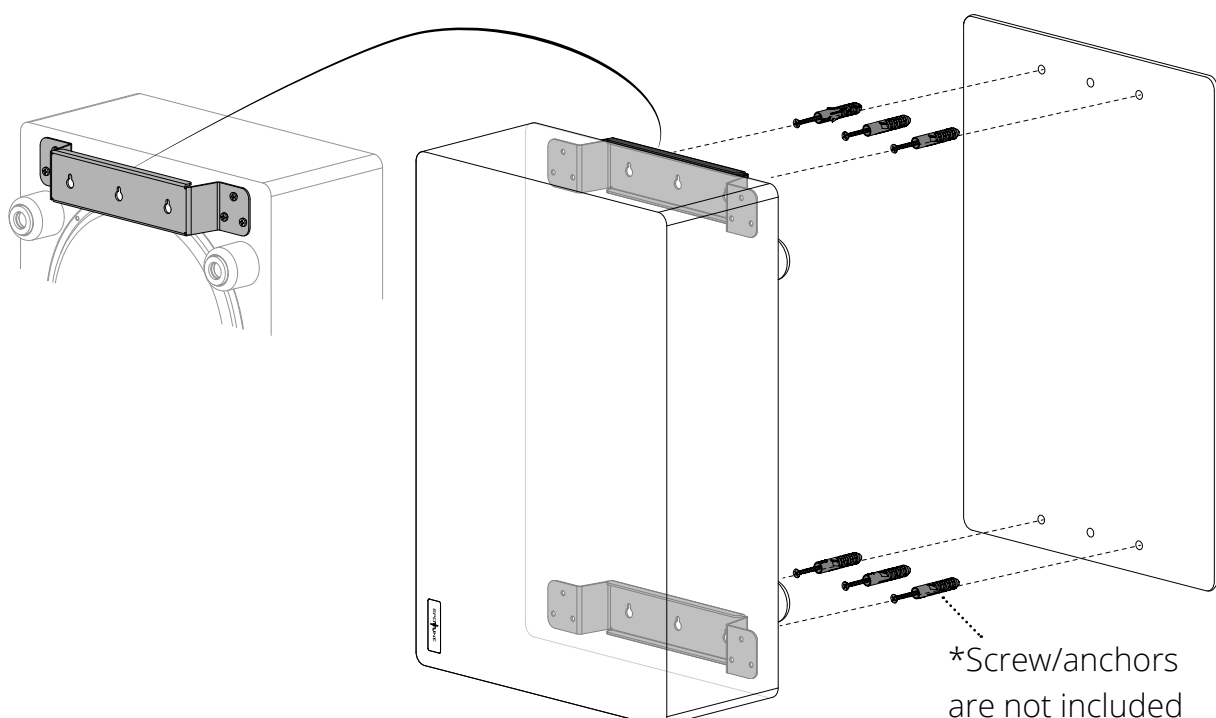

Mounting : Ceiling

WARNING WHEN INSTALLING, ALWAYS OBSERVE THE NATIONAL INSTALLATION AND ACCIDENT PREVENTION REGULATIONS

IMPORTANT ALWAYS CONSULT WITH A PROFESSIONAL INSTALLER.

Utilizing the wall brackets in combination with eye/ring-bolts, enables the possibility of hanging the Spottune Sub from the ceiling, in a wire hanging system.

Find ring/eye-bolts, split lock washers, lock nuts, wires and ceiling anchors, suitable for the ceiling type vs weight of Spottune Sub.

Place and mount 4x ring-bolts in each corner of the premounted wall-brackets. Remember to use locking washer and lock nuts (illustration 1).

Minimum requirements for mounting suspended from the ceiling:

Ring-bolt: M8, minimum requirement 20 kg per bolt

Wire system: minimum requirement 20 kg per wire

Ceiling anchors: minimum requirement 20 kg per anchor

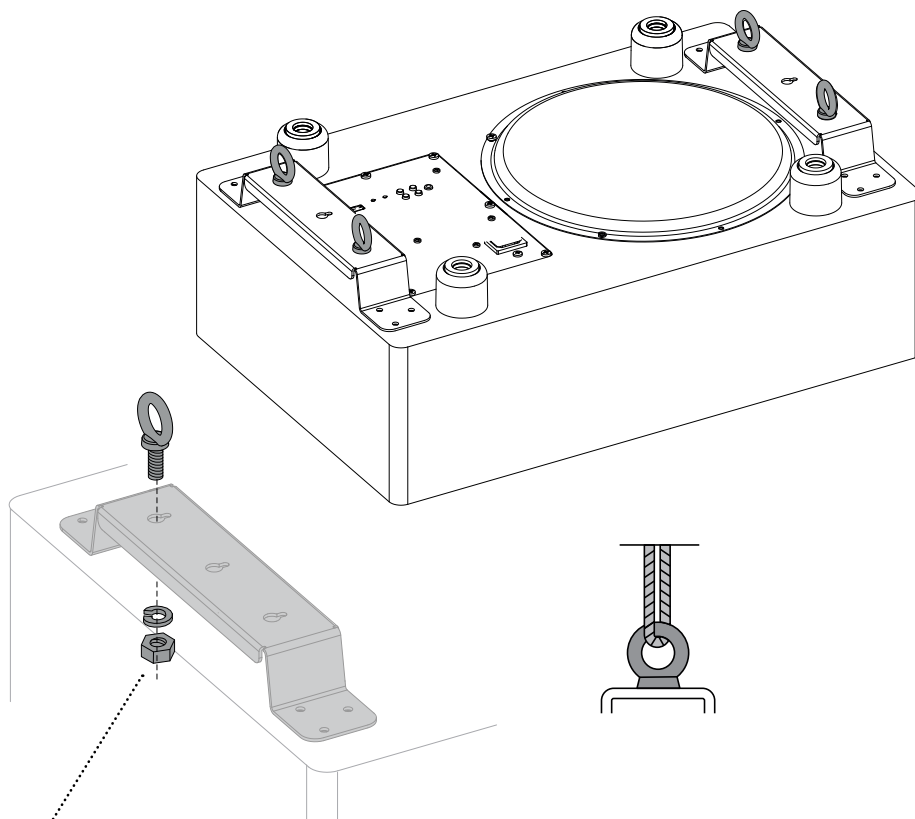

*Bolts are not included.

5. PACKAGING CONTENT

Spottune SUB packaging contains:

- Spottune SUB
- User Manual
- Mounting template (For wall mounting)
- Schuko - IEC powercord

NOTE: Screws, anchors, and etc. for wall and ceiling installation are not included

6. TECHNICAL SPECIFICATIONS

Colors	White / Black / Grey
Specifications	Wireless Smart Subwoofer 200 Watt high efficiency digital Class-D power amplification 10 Inch (250 mm) long stroke driver with extended linear excursion. Microphone sound level accessed from Stream & Cloud Closed box design for optimum performance and extended low-frequency performance.
Frequency	Audio frequency range 20-200Hz Cutoff variable low pass digital filters: 60, <u>80</u> , 100, 120, 160 and 200Hz controlled by Stream & Cloud
Amplification	~200W class D amplifier Max SPL 100dB
Wireless Features	Audio-BroadCasting-Digital - Technology RF-Band 1,8 –1,9 GHz Range up to 50-100m (Condition dependent)
Controls	Wireless input Volume, Zone 1 & 2 AUX input
Dimensions	Height: 200 mm Width: 360 mm Length: 540 mm
Weight	12 Kg
Standby power consumption	1,4 W
SKU	W1 - F - B, W1 - F - G, W1 - F - W

7. COMPLIANCE & LICENSE

This device complies with Part 15 of the FCC Rules. Operation is subject to the following two conditions:

1. This device may not cause harmful interference, and -
2. This device must accept any interference received, including interference that may cause undesired operation.

NOTE: This product has been tested and found to comply with the limits for a Class B digital device, pursuant to Part 15 of the FCC Rules. These limits are designed to provide reasonable protection against harmful interference in a residential installation. This product generates, uses, and can radiate radio frequency energy and, if not installed and used in accordance with the instructions, may cause harmful interference to radio communications. However, there is no guarantee that interference will not occur in a particular installation. If this product does cause harmful interference to radio or television reception, which can be determined by turning the equipment off and on, the user is encouraged to try to correct the interference by one or more of the following measures:

- Reorient or relocate the receiving antenna.
- Increase the separation between the equipment and receiver.
- Connect the equipment into an outlet on a circuit different from that to which the receiver is connected.
- Consult the dealer or an experienced radio/TV technician for help.

Please take attention that changes or modification not expressly approved by the party responsible for compliance could void the user's authority to operate the equipment.

NOTE: This device contains licence-exempt transmitter(s)/receiver(s) that comply with Innovation, Science and Economic Development Canada's licence-exempt RSS(s). Operation is subject to the following two conditions:

1. This device may not cause interference.
2. This device must accept any interference, including interference that may cause undesired operation of the device.

Limited by local law regulations, version for North America does not have region selection option.

This equipment complies with FCC/IC RSS-102 radiation exposure limits set forth for an uncontrolled environment. This equipment should be installed and operated with minimum distance 20cm between the radiator & your body.

7. CONFORMITÉ ET LICENCE

Cet appareil est conforme à la partie 15 de la réglementation de la FCC. L'utilisation de cet appareil est soumise aux conditions suivantes :

1. Cet appareil ne doit pas provoquer d'interférences nuisibles et
2. Cet appareil doit tolérer les interférences externes, y compris celles susceptibles de provoquer un dysfonctionnement

REMARQUE Cet appareil a fait l'objet de tests prouvant sa conformité aux limites imposées aux appareils numériques de classe B, conformément à la partie 15 de la réglementation de la FCC. Ces limites sont conçues pour offrir une protection raisonnable contre les interférences nuisibles dans une installation résidentielle. Cet appareil génère, utilise et est susceptible d'émettre de l'énergie à des fréquences radio. À ce titre, s'il n'est pas installé ou utilisé conformément aux instructions, il est susceptible de perturber les communications radio. Cependant, il n'est nullement garanti que de telles perturbations ne se produisent pas dans une installation donnée. Si cet appareil perturbe effectivement la réception de la radio ou de la télévision, ce qui peut être vérifié en allumant et en éteignant l'appareil, vous êtes invité à tenter de

- Réorientez ou déplacez l'antenne de réception.
- Augmentez la distance séparant le matériel du récepteur.
- Connectez l'appareil à une prise reliée à un circuit différent de celui auquel est branché l'amplificateur.
- Consultez votre revendeur ou un technicien radio/TV expérimenté pour obtenir de l'aide.

Veillez noter que les changements ou modifications non expressément approuvés par la partie responsable de la conformité pourraient annuler l'autorisation de l'utilisateur à utiliser l'équipement.

REMARQUE Ce dispositif contient un ou plusieurs émetteurs/récepteurs exempts de licence qui sont conformes au(x) RSS exempt(s) de licence d'Innovation, Sciences et Développement économique Canada. Le fonctionnement est soumis aux deux conditions suivantes :

1. Cet appareil ne doit pas provoquer d'interférences.
2. Cet appareil doit accepter toute interférence, y compris celles qui peuvent causer un fonctionnement non désiré du dispositif.

Limitée par les réglementations locales, la version pour l'Amérique du Nord ne comporte pas d'option de sélection de la région.

Cet équipement est conforme aux limites d'exposition aux radiations FCC/IC RSS-102 établies pour un environnement non contrôlé. Cet équipement doit être installé et utilisé à une distance minimale de 20 cm entre le radiateur et votre corps.

SPOTTUNE | Denmark

www.spottune.com